

NIVOFIX®

See Vibrachoc
metallic range :
V43 - V44 - V45 - V46



DESCRIPTION

The NIVOFIX mounting is an adjustable equipment foot comprising a circular disc bonded to a protected elastomer base. An adjustment screw is fitted into the assembly.

The elastomer base has anti-slip ridges.

OPERATION

The design of the NIVOFIX mounting gives the following basic characteristics :

- Accurate adjustment of the mounting to correct the equipment's seating (adjustment screw, correction of altitude).
- Absorbs high frequency vibrations.
- Corrosion resistant (nitrile elastomer, protective shroud, galvanised metallic parts).
- Anti-slip sole (no need to fix).

Advantages :

- Speed of fixing.
- Simple removal of the equipment.
- No shimming.

DIMENSIONS

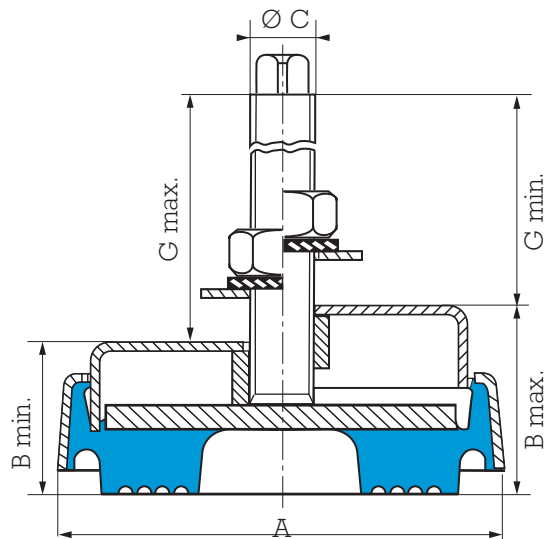

| Reference Stainless steel | Reference Steel | A mm | B mm | | | $\varnothing C$ | G mm | | Weight g | Stud length mm |
|---------------------------------|--------------------|---------|------------------------------|------|----|-----------------|------|------|-------------|----------------------|
| | | | B maxi = B mini + adjustment | | | | mini | maxi | | |
| 530815 | 530810 | 65 | 31.5 | 26.5 | 5 | M12 | 105 | 110 | 280 | 120 |
| 530825 | 530820 | 88 | 46 | 33 | 13 | M16 | 114 | 127 | 690 | 200 |
| 530835 | 530830 | 133 | 58 | 46 | 12 | M20 | 130 | 142 | 1820 | 250 |
| | 530840 | 200 | 70 | 58 | 12 | M24 | 145 | 157 | 5250 | 300 |
| | 530850 | 260 | 83 | 65 | 18 | M24 | 158 | 176 | 10000 | 300 |

See current price list for availability of items.

OPERATING CHARACTERISTICS

| Reference | Nominal static load min - max in daN | Deflection mm |
|-----------|--|------------------|
| 530810 | 100 - 600 | 1 - 3.5 |
| 530815 | 100 - 600 | 1 - 3.5 |
| 530820 | 325 - 1300 | 2 - 4 |
| 530825 | 325 - 1300 | 2 - 4 |

| Reference | Nominal static load min - max in daN | Deflection mm |
|-----------|--|------------------|
| 530830 | 650 - 2600 | 2 - 4 |
| 530835 | 650 - 2600 | 2 - 4 |
| 530840 | 1500 - 6000 | 1.5 - 3 |
| 530850 | 3000 - 12000 | 2 - 4 |

1 kg = 1 daN

APPLICATIONS

NIVOFIX mountings are used for all equipment requiring height adjustment.

Equipment already using NIVOFIX mountings:

- Vertical mill
- Mortiser
- Multichuck drill
- Sheet metal bender
- Polisher
- Press
- Plane
- Horizontal mill
- Lathe
- Office equipment
 - accounting
 - computing
- Packaging machine
- Test equipment
- Printing press
- Gear cutter
- Textile machinery

